

Thick Film Chip Resistor Arrays - Concave Terminal

Performance Specification

Short Time Overload	$\pm(2.0\% + 0.1\Omega)\text{Max}$
Terminal Bending	$\pm(1.0\% + 0.05\Omega)\text{Max}$
Soldering Heat	$\pm(1.0\% + 0.05\Omega)\text{Max}$
Insulation Resistance	Min. 1,000 Mega Ohm
Solderability	Min. 95% coverage.
Temperature Cycling	$\pm(1.0\% + 0.05\Omega)\text{Max}$
Load Life in Humidity	$\pm(3.0\% + 0.1\Omega)\text{Max}$
Load Life	$\pm(3.0\% + 0.1\Omega)\text{Max}$
Dielectric Withstanding Voltage	No evidence of flashover, mechanical damage, arcing or insulation breakdown.

Ordering Procedure: Ex.: RMC 1/16W (2C02), +/-1%, 10 Ω , T/R5000

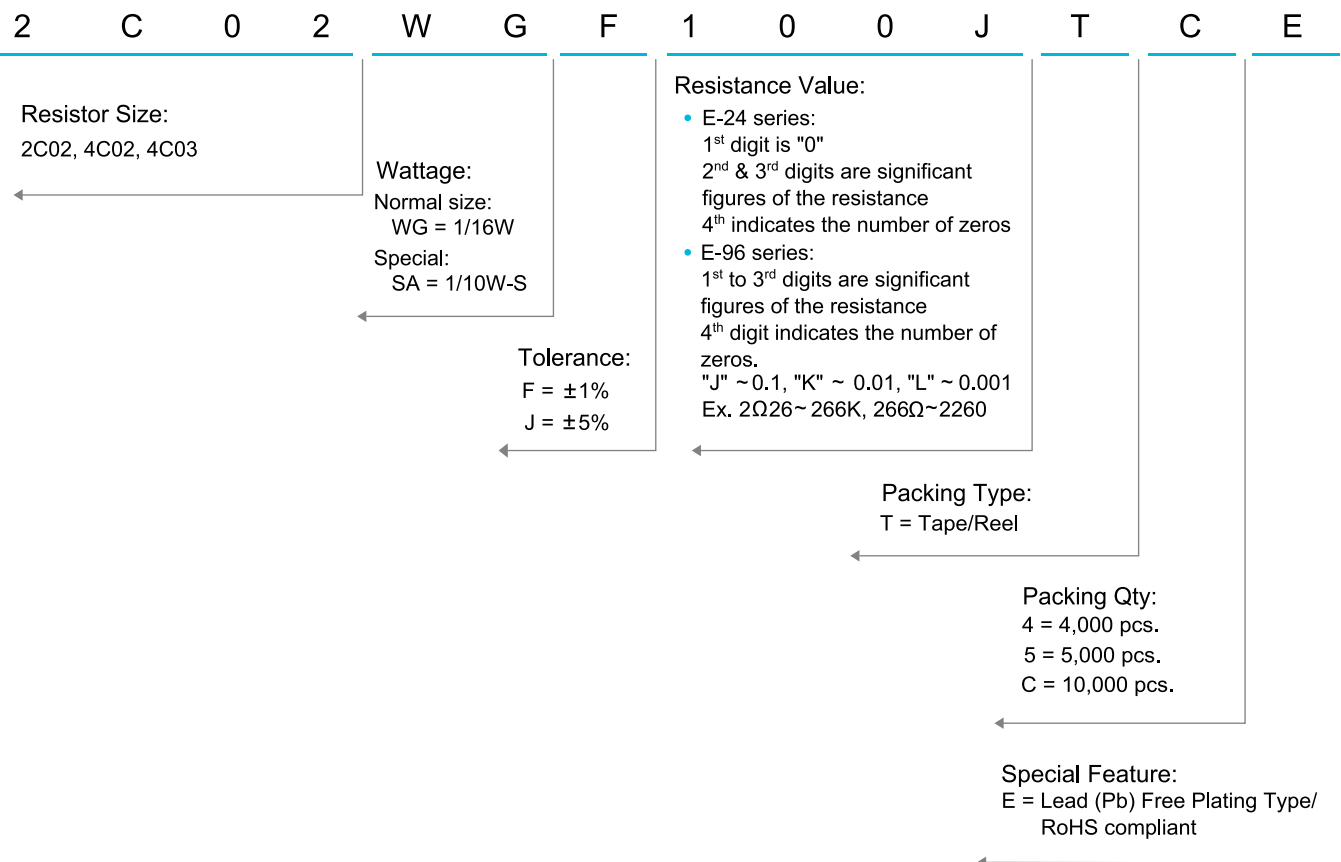

Thick Film Chip Resistor Arrays - Concave Terminal



Features

- High density, more than 1 resistors in one small case
- The concave designed in terminal enlarge the soldering plate area
- Concave is design to reduce the terminal breaking risk
- Improvement of placement efficiency
- Application: RAM, CD & DVD Rom, Hard Disk, Master board

Standard : 2% ,5% ,10% -- E - 24 series
1% -- E - 96 series

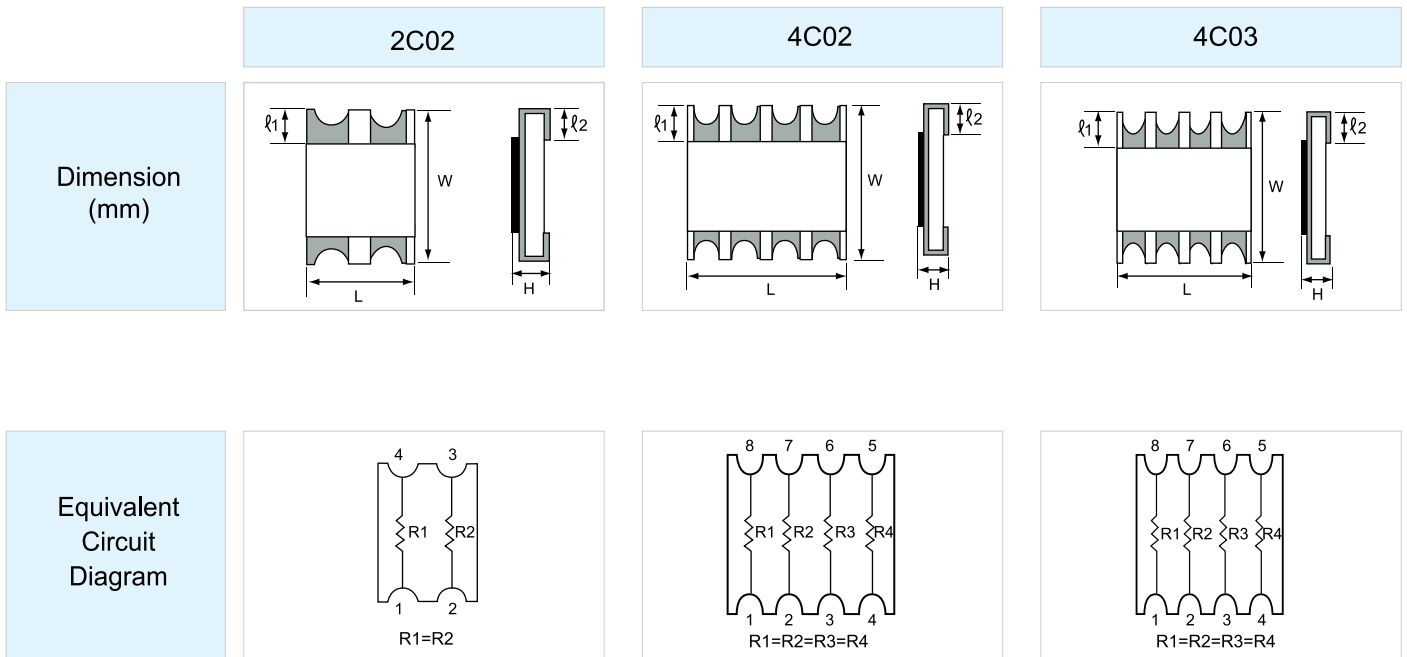

Type	Style	L	W	H	l ₁	l ₂
2C02	2C02 (4Pin 2R)	1.00±0.10	1.00±0.10	0.35±0.10	0.15±0.10	0.30±0.10
4C02	4C02 (8Pin 4R)	2.00±0.10	1.00±0.10	0.45±0.10	0.15±0.10	0.30±0.10
4C03	4C03 (8Pin 4R)	3.20±0.20	1.60±0.20	0.60±0.10	0.30±0.20	0.40±0.10

Type	Style	Power Rating at 70°C	Max Working Voltage	Max Overload Voltage	Dielectric Withstanding Voltage	T.C.R. PPM/°C	Resistance Range		Jumper Rated Current
							F(±1%)	J(±5%)	
2C02	2C02 (4Pin 2R)	1/16W	50V	100V	100V	±200	10Ω ~ 1MΩ	10Ω ~ 1MΩ	1A
4C02	4C02 (8Pin 4R)	1/16W	50V	100V	100V	±200	10Ω ~ 1MΩ	10Ω ~ 1MΩ	1A
4C03	4C03 (8Pin 4R)	1/16W 1/10W-S	50V	100V	300V	<10Ω : ±400 ≥10Ω : ±200	1Ω ~ 1MΩ	1Ω ~ 1MΩ	1A

Standard Operating Temp (°C) : -55~+155