

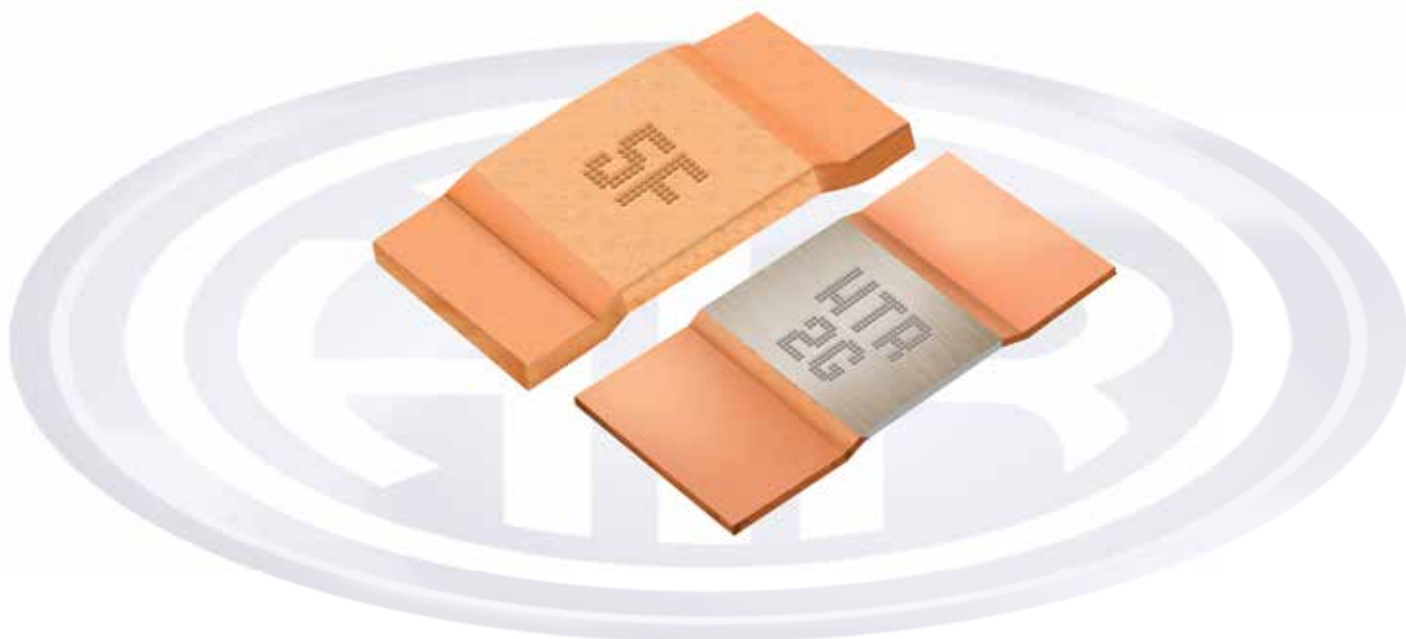

**LOW OHM  
POWER RESISTORS**

**HSE  
SERIES  
Size 3920**

- Open frame electron beam welded punched out type.
- Power Rating at 100°C - upto 5W.
- Power Rating at 70°C - upto 12W.
- R0002 to R005.





LOW OHM  
POWER  
RESISTORS  
**HSE**  
SERIES  
Size 3920

## PHYSICAL CONFIGURATION

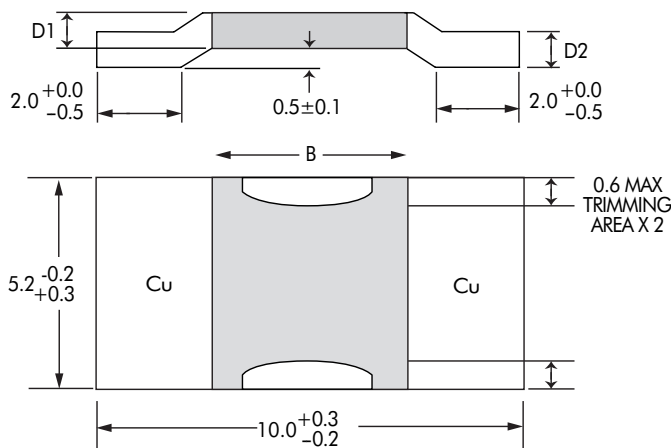

## DIMENSIONAL TABLE

SR NO.	HI-TECH PART NAME	WATTAGE AT 100°C	WATTAGE AT 70°C	B (MM)	D1 (MM)	D2 (MM)	INTERNAL HEAT RESISTANCE (Rthi)	TCR (ppm)	TYPICAL WT. PER PC. (Gms)
1	HSE5W R0002 F	5W	12W	5.0 (+0.2/-0.3)	1.42 ± 0.10	1.42 ± 0.10	3°K/W	< 200	0.73
2	HSE5W R0003 F	5W	10W	5.0 (+0.2/-0.3)	1.42 ± 0.10	1.42 ± 0.10	4.5°K/W	< 150	0.73
3	HSE5W R0005 F	5W	9W	5.0 (+0.2/-0.3)	0.84 ± 0.10	0.84 ± 0.10	8°K/W	< 70	0.40
4	HSE5W R0007 F	5W	8W	5.0 (+0.2/-0.3)	0.60 ± 0.10	0.60 ± 0.10	11°K/W	< 60	0.29
5	HSE5W R001 F	5W	8W	5.0 (+0.2/-0.3)	1.36 ± 0.10	1.36 ± 0.10	9°K/W	< 50	0.64
6	HSE4.5W R0015 F	4.5W	7W	5.0 (+0.2/-0.3)	0.91 ± 0.10	0.91 ± 0.10	12°K/W	< 50	0.43
7	HSE4W R002 F	4W	6W	5.0 (+0.2/-0.3)	0.68 ± 0.10	0.68 ± 0.10	16°K/W	< 50	0.31
8	HSE4W R001F	4W	7W	5.0 (+0.2/-0.3)	0.42 ± 0.10	0.42 ± 0.10	15°K/W	< 50	0.20
9	HSE3.5W R0025 F	3.5W	6W	5.0 (+0.2/-0.3)	0.54 ± 0.10	0.54 ± 0.10	20°K/W	< 50	0.25
10	HSE3W R003 F	3W	5W	5.0 (+0.2/-0.3)	0.45 ± 0.10	0.45 ± 0.10	22°K/W	< 50	0.21
11	HSE3W R0028 F	3W	5W	5.0 (+0.2/-0.3)	0.47 ± 0.10	0.47 ± 0.10	21°K/W	< 50	0.21
12	HSE2.5W R004 F	2.5W	4W	5.0 (+0.2/-0.3)	0.34 ± 0.10	0.34 ± 0.10	30°K/W	< 50	0.17
13	HSE2W R005 F	2W	3W	5.0 (+0.2/-0.3)	0.27 ± 0.10	0.27 ± 0.10	50°K/W	< 50	0.15
14	HSE R000	I <sub>max</sub> = 160A			1mm copper				0.60

## APPLICATIONS

- Accurate current sensing for power hybrid applications.
- Automotive applications that require high current capability.
- Frequency converters.
- Power modules.

## FEATURES

- Capable of carrying current upto 160amp (R0002) on continuous basis.
- Sturdy copper connectors.
- Excellent long term stability.

PARAMETER / PERFORMANCE TEST & TEST METHOD	PERFORMANCE REQUIREMENTS
<b>Power Rating</b>	For FeCrAl - Full power dissipation at 70° C and linearly derated to zero at +170° C. For Manganin (< 0.5% Improved Stability) - Full power dissipation at 100° C & linearly derated to zero at +140° C. For Manganin (< 1% Stability) - Full power dissipation at 130° C and linearly derated to zero at +170° C.
<b>Inductance</b>	< 3nH
<b>Resistance Tolerance</b>	± 1% (0.5% and other tolerance available on request)
<b>Temperature Range</b>	- 55° C to +170° C (Suitably derated as per derating curve provided)
<b>Voltage Rating / Limiting Voltage / Max. Working Voltage</b> (Subject to max. Terminal Temperature of 120° C)	$\sqrt{P \times R}$
<b>Low Temperature Storage and Operation</b> [-65° C for 24 h]	$\Delta R \pm 0.1\%$ - Average
<b>Temperature Coefficient of Resistance</b> (Ambient Temperature Range 20° C - 60° C)	From 50 ppm / K (Depending on Resistance Value)
<b>Temperature Cycling -2000 cycles</b> (-55° C to 150° C)	$\Delta R \pm 0.5\%$ - Average
<b>Life Test / Operational Life - 2000 h rated power with Temperature limitation on Terminal kept at 120° C</b>	$\Delta R \pm 1\%$ - Average
<b>Moisture Resistance</b> [MIL-STD-202 method106]	$\Delta R \pm 0.1\%$ - Average
<b>Mechanical Shock</b> [100 g. 6 ms half sine]	$\Delta R \pm 0.2\%$ - Typical
<b>Vibration, High Frequency</b> [20 g. 10-2000 Hz]	$\Delta R \pm 0.2\%$ - Typical
<b>Bias Humidity</b> [+85° C, 85% RH, 1000h]	$\Delta R \pm 0.5\%$ - Typical

**RECOMMENDED SOLDER PROFILE**

Reflow and IR soldering			
Temperature (°C)	260	255	217
Time (Sec)	Peak	40	90

**RECOMMENDED PCB - LAYOUT**

Recommended PCB layout for high precision applications

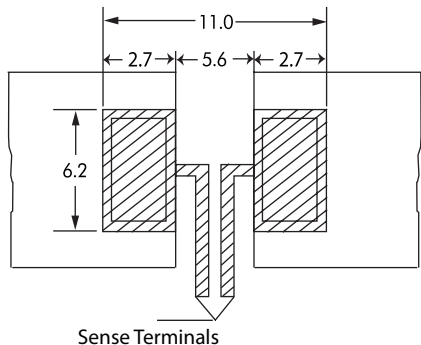

Recommended PCB layout for normal application

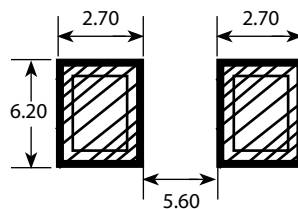

**PACKAGING**

**A. BULK**

Resistors shall be packed in plastic Box-K44 of approximate size 162x104x37mm- 2000pcs/box & this box will be vacuum sealed with polythene of 100 micron. With enclose silica gel.

**B. TAPE & REEL PACKING**

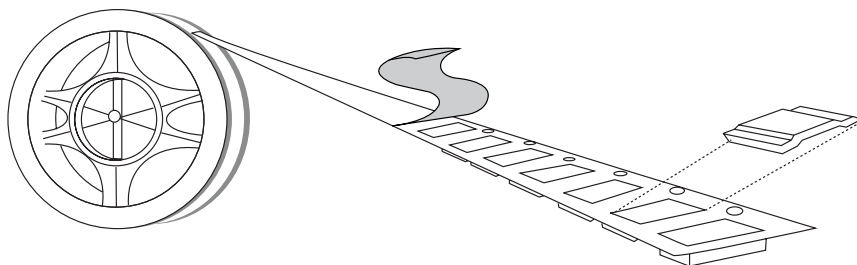

SPECIFICATION	TAPEWIDTH	PARTS PER REEL
EIA-481-D	16mm	3000 pcs

Storage Condition (Packed) : Temp 25°C to 35°C, Humidity 30 to 80% RH, Shelf life-12 months

Floor Life (Unpacked) : Temp 25°C to 35°C, Humidity 30 to 80% RH, Floor life-15 days

**MARKING**

HTR PART NO	PRINTING
HSE5W R0002 F	HTR HSE R0002 1% DATECODE

**ORDERING INFORMATION**

SERIES	TYPE	PACKING	RESISTANCE VALUE	TOLERANCE
HSE	HSE5W	Bulk - HSE5W Tape & Reel - HSE5WTR	R001	±1%

Part no of HSE5W, Tape and reel with resistance value R001 and 1% tolerance will be HSE5WTR R001 ±1%



LOW OHM  
POWER  
RESISTORS  
**HSE**  
SERIES  
Size 3920

**TYPICAL POWER DERATING CURVE FOR RESISTOR WHEN FULL POWER IS AT 100°C & 130°C**

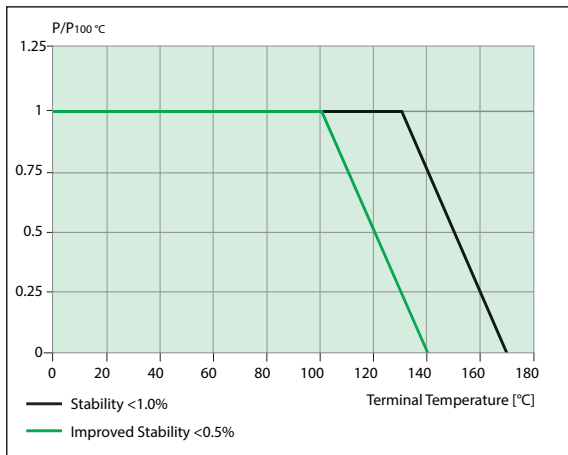

**TYPICAL POWER DERATING CURVE FOR RESISTOR WHEN FULL POWER IS AT 70°C**

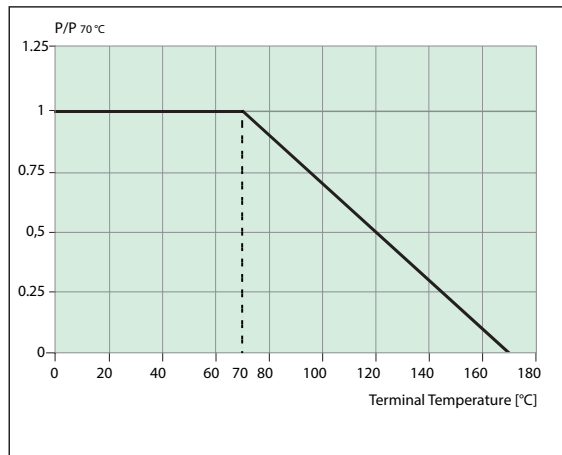

In case the Design Engineer requires a specific graph of a particular component it can be supplied on request.

**MAXIMUM PULSE ENERGY WITH RESPECT TO PULSE POWER FOR PERMANENT OPERATION**

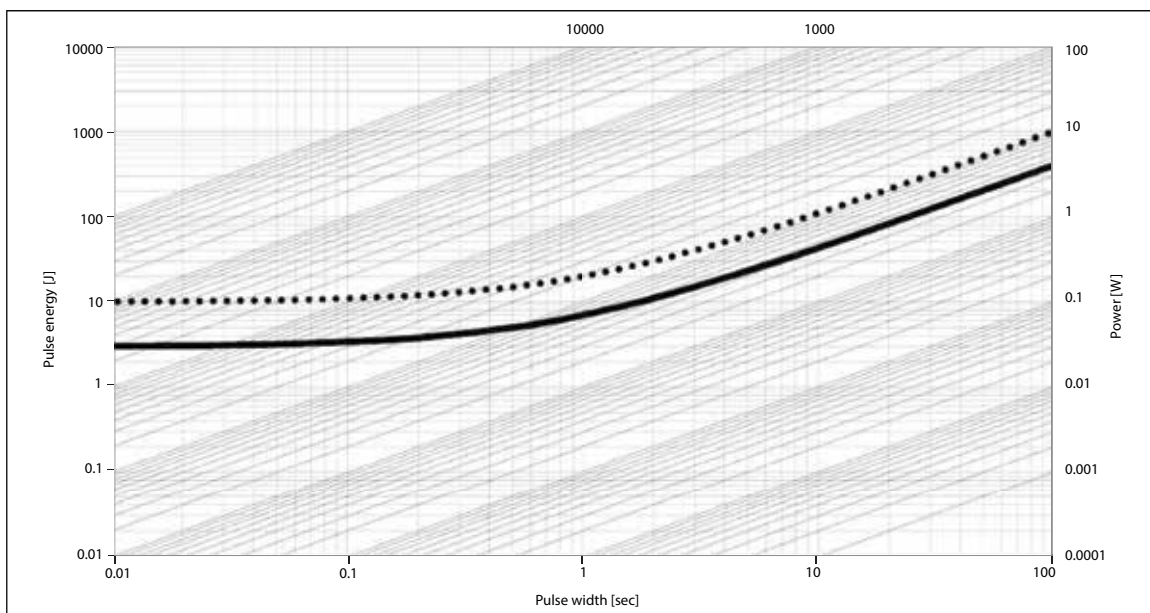

In this graph the max. & min. curve are shown as **•••** and **—** for all resistance values, the area between the max. & min. curve is applicable. In case the Design Engineer requires a specific graph of a particular component it can be supplied on request.

**TYPICAL TEMPERATURE DEPENDANCE OF THE ELECTRICAL RESISTANCE**

